



VITRINA REFRIGERADA - CRISTAL CURVO - GRUPO REMOTO



Modelos MAR - Parrillas/B.Plana



CARACTERÍSTICAS GENERALES

- Construída totalmente en Acero Inoxidable AISI-304
- Unidad condensadora remota protegida y conectada por tubo de 1.8m con carga de gas R-134a.
- Cristal curvo fijo (los modelos 250 y 300 - 2 cristls).
- Puertas abatibles en metacrilato.
- Iluminación LED.
- Temperatura de trabajo +1 °C / +5° C.
- Interruptores impermeabilizados.
- Inyectado interior en poliuretano libre de CFCs.



CARACTERÍSTICAS TÉCNICAS

	Dimensiones (LxPxH)	Parrillas
MAR-120	120 x 38 x 18 cm	2
MAR-150	150 x 38 x 18 cm	3
MAR-200	200 x 38 x 18 cm	4
MAR-250	250 x 38 x 18 cm	5
MAR-300	300 x 38 x 18 cm	6

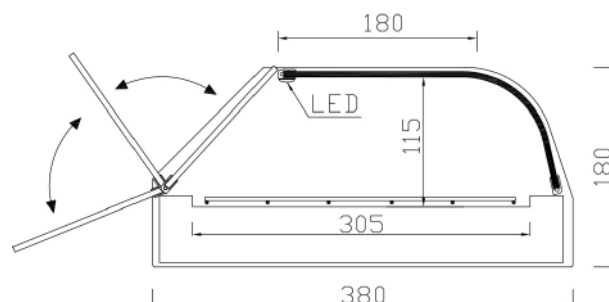

Blanco

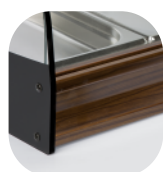

Nogal

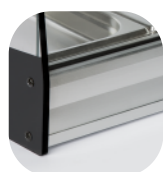

Plata

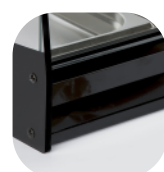

Negro