

FIRMADO POR: Fº JAVIER ROMERO	REFERENCIA: FG300	ESPESOR:	A4
	NOMBRE DE PIEZA: FOGON 300 SERIE 500 2019	MATERIAL: Material <sin especificar> PESO: 8668.86 gr	VERSIÓN: 10/03/2020 7:16:36 Escala 1:8 FECHA CREACIÓN: 19/05/2015 Hoja 1 de 3
			Pol. Ind. Mantón de Manila M-3 Parc- 22 CP. 14940 CABRA (Cordoba) TLFNO: 957-52-54-64 FAX: 957-52-46-64

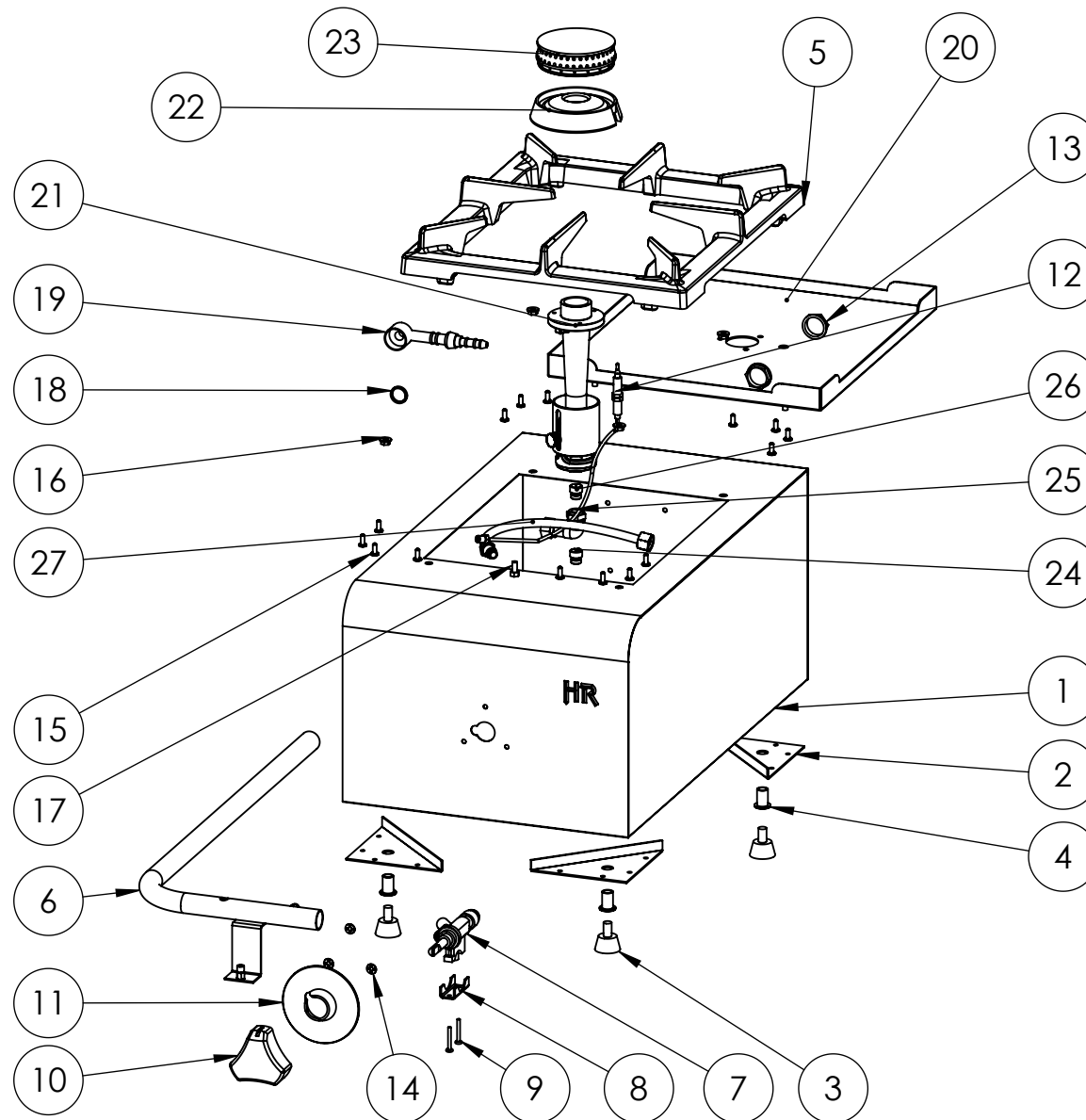

FIRMADO POR: Fº JAVIER ROMERO	REFERENCIA: FG300	ESPESOR:	A4
	NOMBRE DE PIEZA: FOGON 300 SERIE 500 2019	MATERIAL: Material <sin especificar> PESO: 8668.86 gr	VERSIÓN: 10/03/2020 7:16:36 Escala 1:7 Hoja 2 de 3
			Pol. Ind. Mantón de Manila M-3 Parc- 22 CP. 14940 CABRA (Cordoba) TLFNO: 957-52-54-64 FAX: 957-52-46-64

N.º DE ELEMENTO	N.º DE PIEZA	DESCRIPCION	CANTIDAD
1	CUERPO SOLDADO FG300 SERIE 500	110002908	1
2	REFUERZO PATA SERIE 500	110002883	4
3	PIE DE GOMA D 8mm	110001023	4
4	REMACHE ROSCA M8	110001106	4
5	PARRILLA OMNIA 300X335mm ESMALTAD NEGRO MATE	110002707	1
6	TUBO GAS FG300 SERIE 500	110002915	1
7	GRIFO C-SEG 1VIA C-JUNTA CE10	110001028	1
8	BRIDA 2 TORN. RAMPA 1/2" GAS	110001027	1
9	TORNILLO PARA BRIDA 4282-8	110001253	2
10	MANDO CROMADO HR EJE 90º	110002812	1
11	EMBELLECEDOR MANDO PLANCHA	110002773	1
12	TERMOPAR 2º SERIE M8X1 L=320 CR	110001025	1
13	TUERCA LATON 1-2 TUBO PLANCHA	110001273	2
14	SUJECCION RAPIDA CIRCULAR SRM 4 COD. 0211038-8	110002907	3
15	REMACHE A-2 INOXINOX 4X6 5973	110003149	16
16	TUERCA M5 DIN6923 ZN	110001950	4
17	TORNILLO M5X10 DIN933	9336805010	1
18	JUNTA TECNOFREE(KLINGERIT)	110001257	1
19	PORTAGOMA ANGULO 90º 1-2 GNAT+GBUT	110001256	1
20	BANDEJA FG300 2019 SERIE 500 SOLDADA	110004893S	1
21	VENTURI QUEMADOR VERTICAL SERIE M 6 KW	110004816	1
22	CUERPO QUEMADOR VERTICAL SERIE M 6 KW	Incluido en 110004816	1
23	DIFUSOR QUEMADOR VERTICAL SERIE M 6 KW D75	Incluido en 110004816	1
24	INYECTOR GAS 1,65 EX 11-M10X1	110001990	1
25	CONJUNTO PORTAINYECTOR M10x1 TUBO 8 BARB 2018	110004150	1
26	INYECTOR GAS BUTANO 1,10 EX 11-M10X1	110003412	1
27	CONJUNTO TUBO CONEXION L=250 BASIC M-H	110003822	1

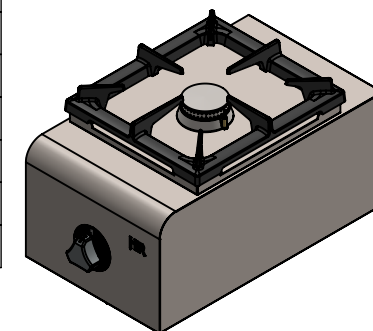

FIRMADO POR: Fº JAVIER ROMERO	REFERENCIA: FG300	ESPESOR:	A4
	NOMBRE DE PIEZA: FOGON 300 SERIE 500 2019		VERSIÓN: 10/03/2020 7:16:36
			Escala 1:12
Pol. Ind. Mantón de Manila M- 3 Parc- 22 CP. 14940 CABRA (Cordoba) TLFNO: 957-52-54-64 FAX: 957-52-46-64	MATERIAL: Material <sin especificar>	FECHA CREACIÓN:	Hoja 3 de 3
	PESO: 8668.86 gr	19/05/2015	